



d
GN
G

Desarrollos
Inmobiliarios

Fideicomiso Don Bosco
Calle Don Bosco 405





Situado en zona residencial, a sólo minutos de las principales calles de la ciudad, se convierte en un excelente lugar para vivir, ya que combina el vivir en una zona tranquila con el fácil acceso al área céntrica.

De tipología horizontal, consta de 2 grandes pulmones de aire en los laterales internos del edificio, con el fin de mejorar la iluminación de cada uno de los locales que este abarca y proponer una mayor amplitud en los mismos.

Se accede mediante un hall común, situado en el centro del edificio, que comunica, en planta baja, con dos locales – depósitos de 230 m² que, sumados al acceso del patio del edificio, alcanzan los 300 m² por unidad aproximadamente.

Las escaleras principales comunican con 18 departamentos de 1, 2 y 3 ambientes distribuidos en 3 plantas, algunos de los cuales están diseñados en dúplex. Completan el proyecto 19 cocheras.

Don Bosco representa una excelente oportunidad de inversión a futuro, debido a que fue comenzado a fines de junio de 2020 por lo que el precio de las unidades es bajo y su proyección a futuro es ascendente.

Una oportunidad ¡para aprovechar!

Fideicomiso Don Bosco
Calle Don Bosco 405

gmdesarrollos.com.ar

FIDEICOMISO DON BOSCO





Especificaciones técnicas:

- Estructura de hormigón armado sismoresistente.
- Muros exteriores e interiores de mampostería.
- Revestimientos exteriores de piedra natural de la zona y siding.
- Terminación interior con enlucido de yeso pintado al látex.
- Cerámicos de primera calidad en pisos y revestimientos de baños y cocinas.
- Porcelanato en pisos de sectores comunes.
- Ventanas de PVC con vidrio termopanel.
- Puertas de madera maciza.
- Placards con frentes e interiores revestidos con melamina imitación madera.
- Artefactos sanitarios y griferías de primera calidad.
- Calefacción por radiadores.
- Materiales aprobados de primera calidad en instalaciones sanitarias, eléctricas, de calefacción y gas.



Fideicomiso Don Bosco
Calle Don Bosco 405

gmdesarrollos.com.ar



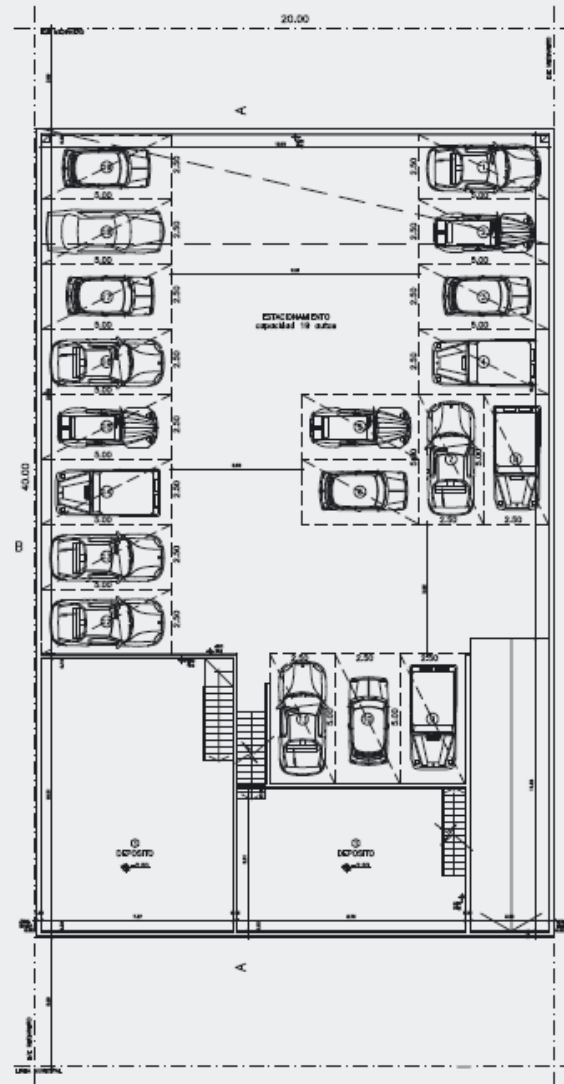

Subsuelo

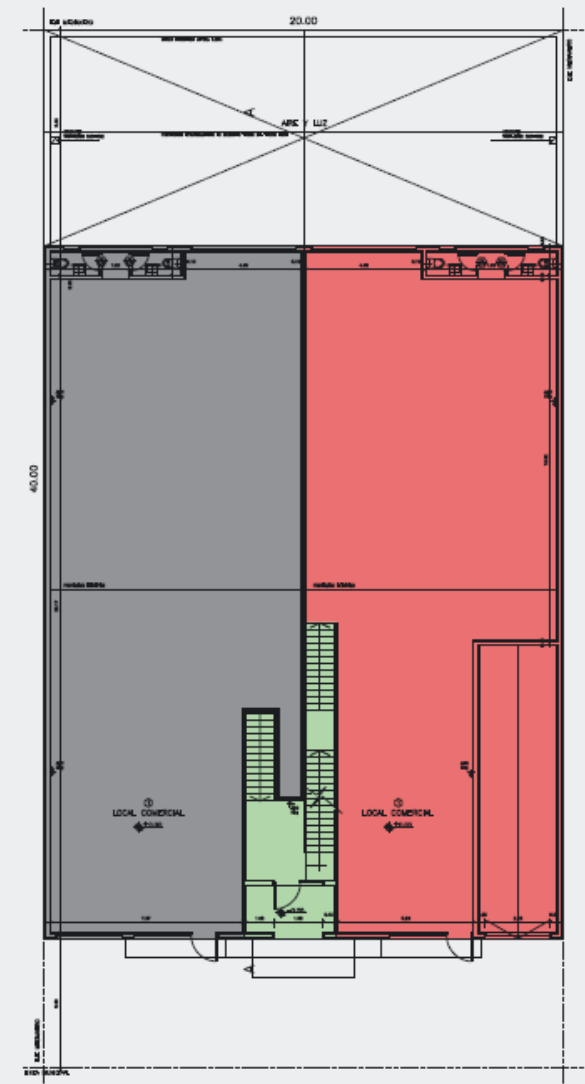

Planta Baja / Locales comerciales

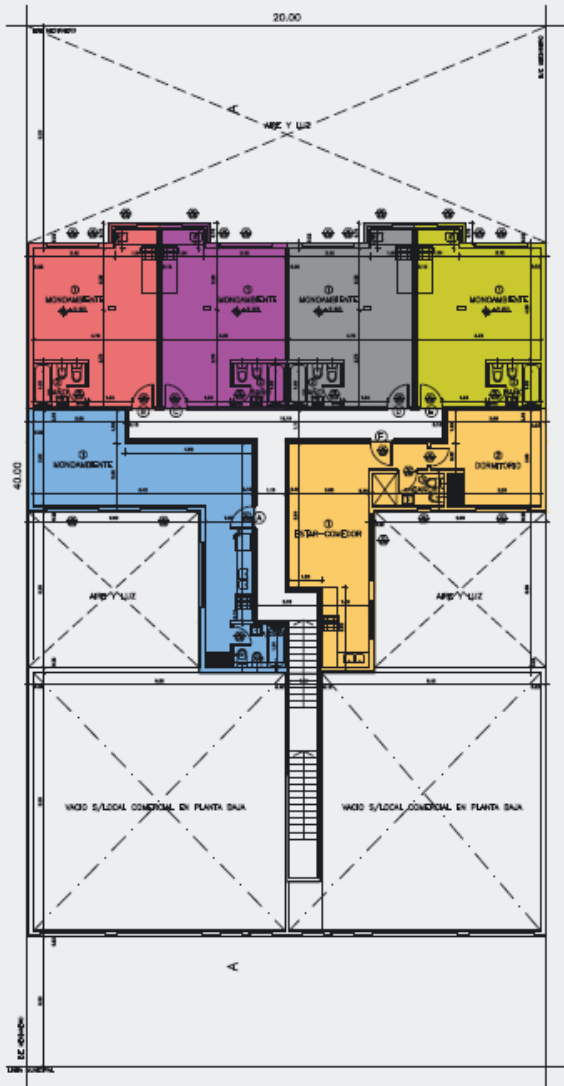

1er Piso

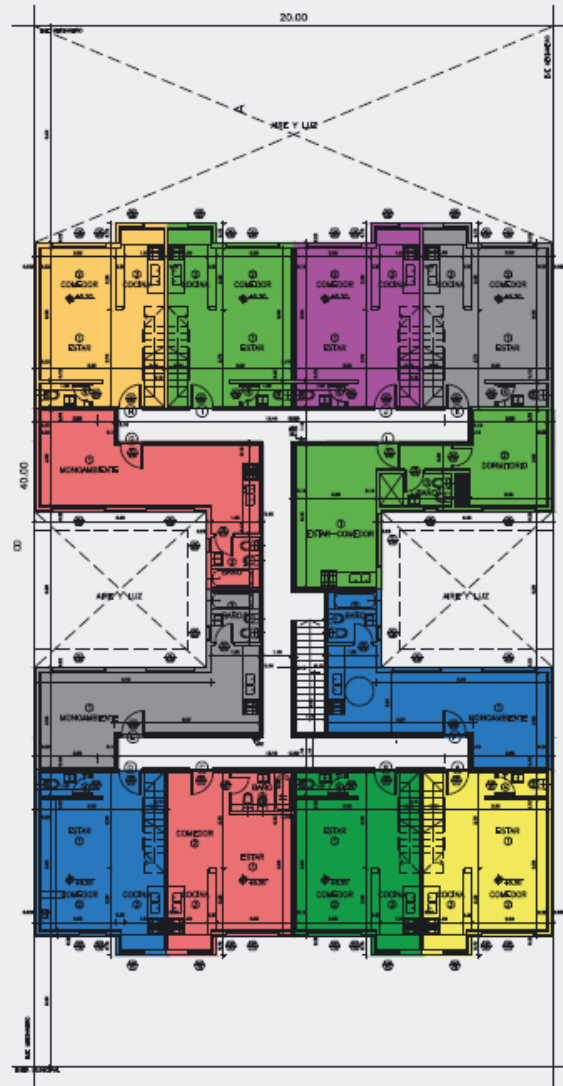

2do Piso

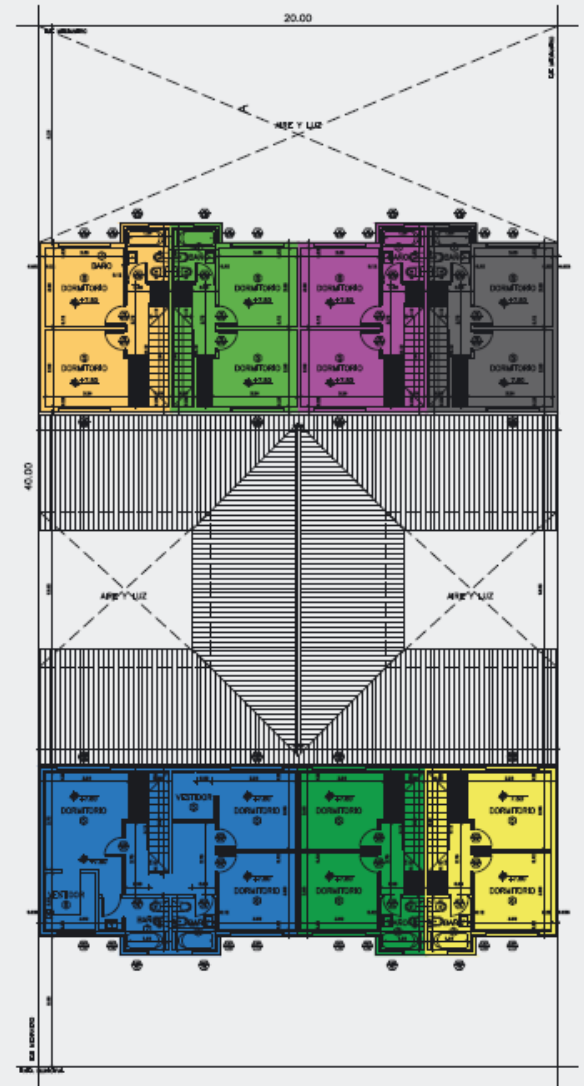

Entre Techo

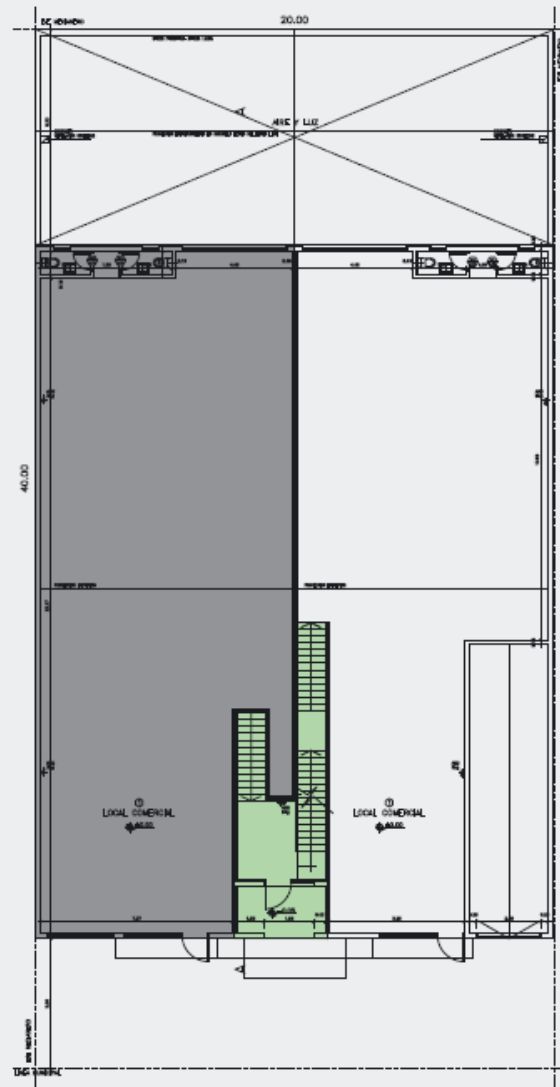

Planta Baja

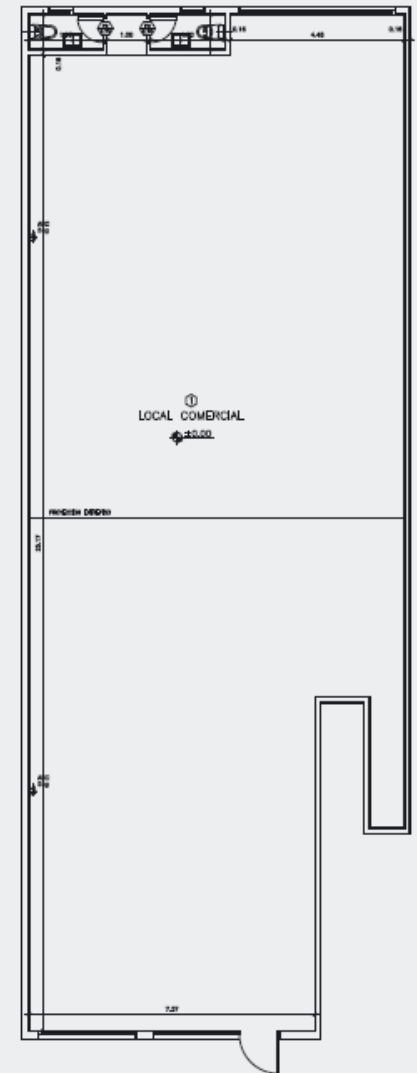

Local 1

Local 233,6 m²
Toilette 1 - 1,7 m²
Toilette 2 - 1,7 m²

Sup. Total 237 m²



Planta Baja

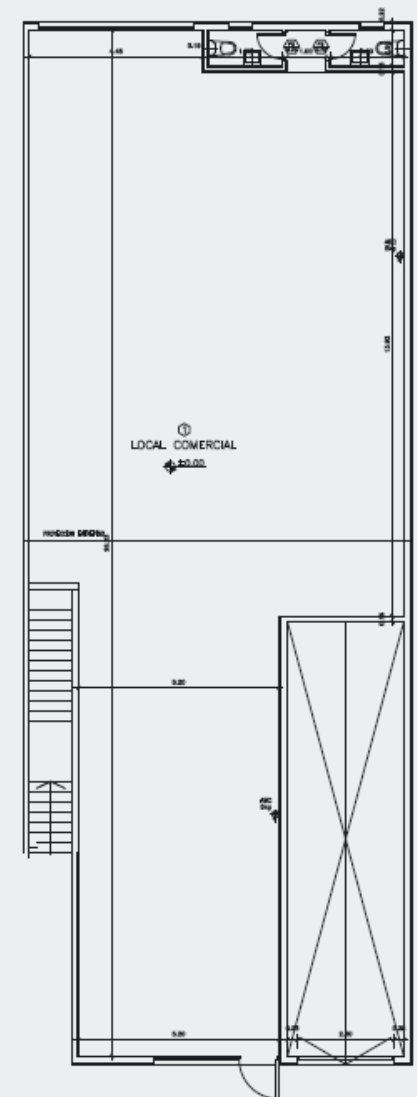

Local 2

Local 210,6 m²
Toilette 1 - 1,7 m²
Toilette 2 - 1,7 m²

Sup. Total 214 m²

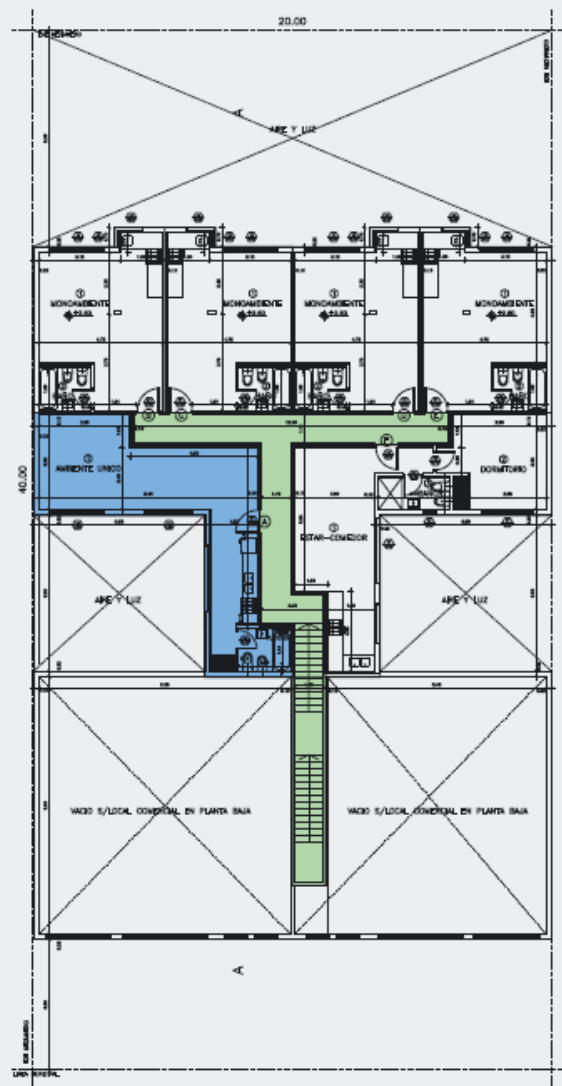

1er Piso

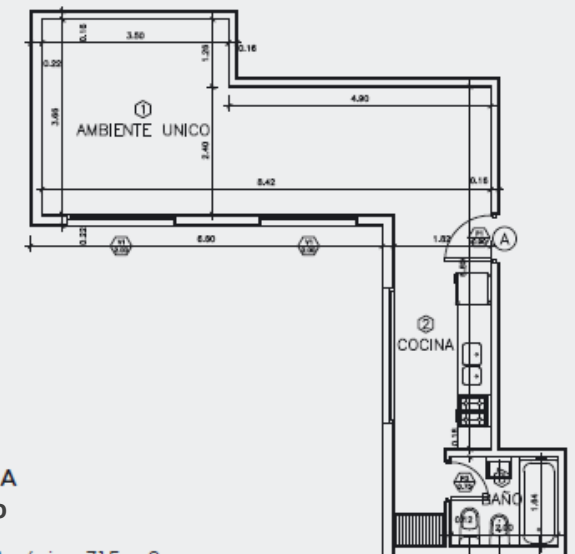

Unidad A
1er Piso

Ambiente único 31,5 m²
Cocina 8,15 m²
Baño 3,35 m²

Sup. Total 43 m²

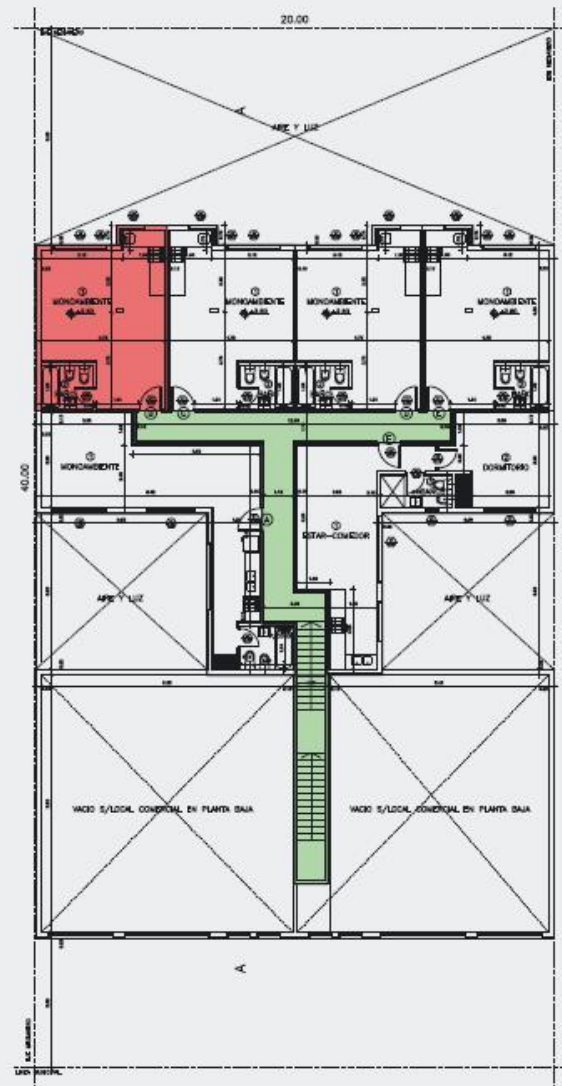

1er Piso

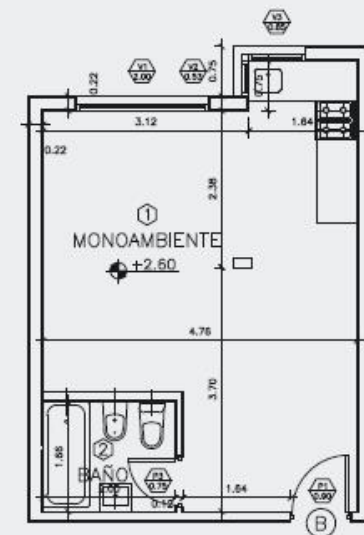

Unidad B
1er Piso

Ambiente Único 29,65 m²
Baño 3,35 m²

Sup. Total 33 m²

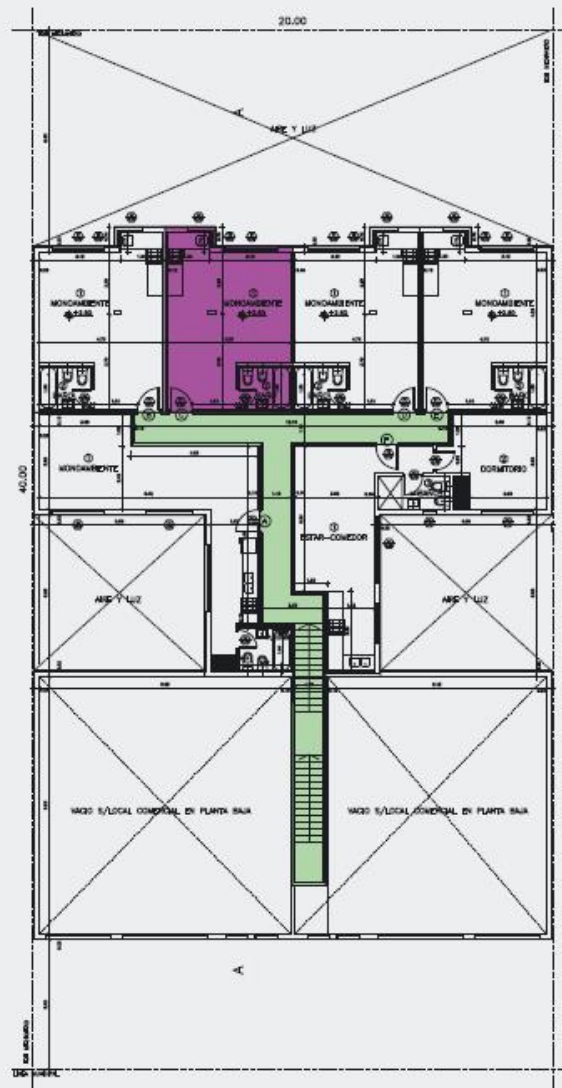

1er Piso



Unidad C
1er Piso

Ambiente único 29,65 m²
Baño 3,35 m²

Sup. Total 33 m²

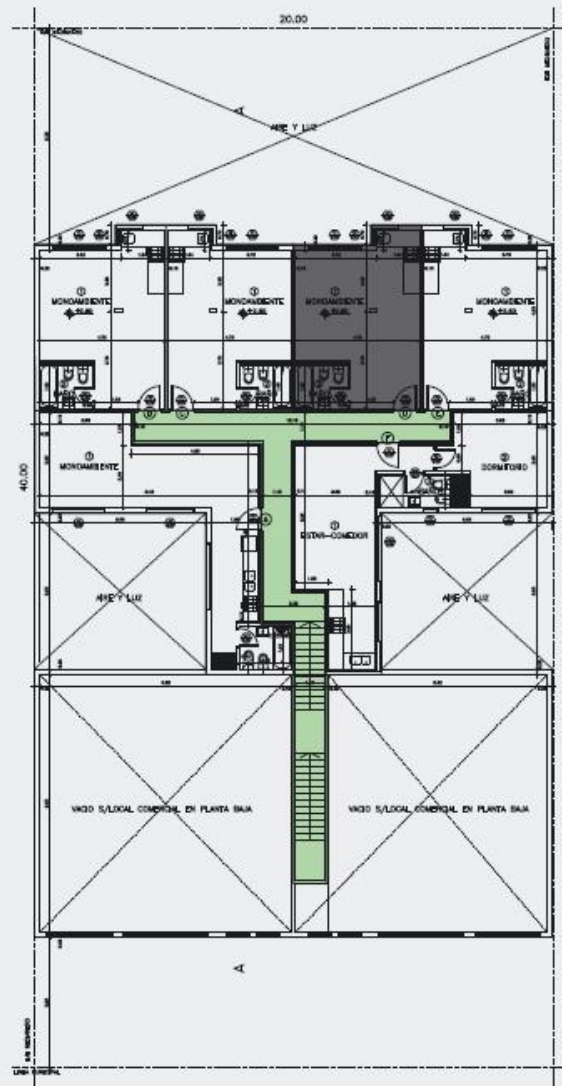

1er Piso

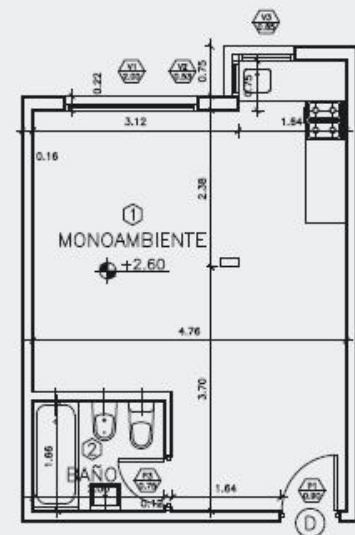

Unidad D
1er Piso

Ambiente Único 29,65 m²
Baño 3,35 m²

Sup. Total 33 m²

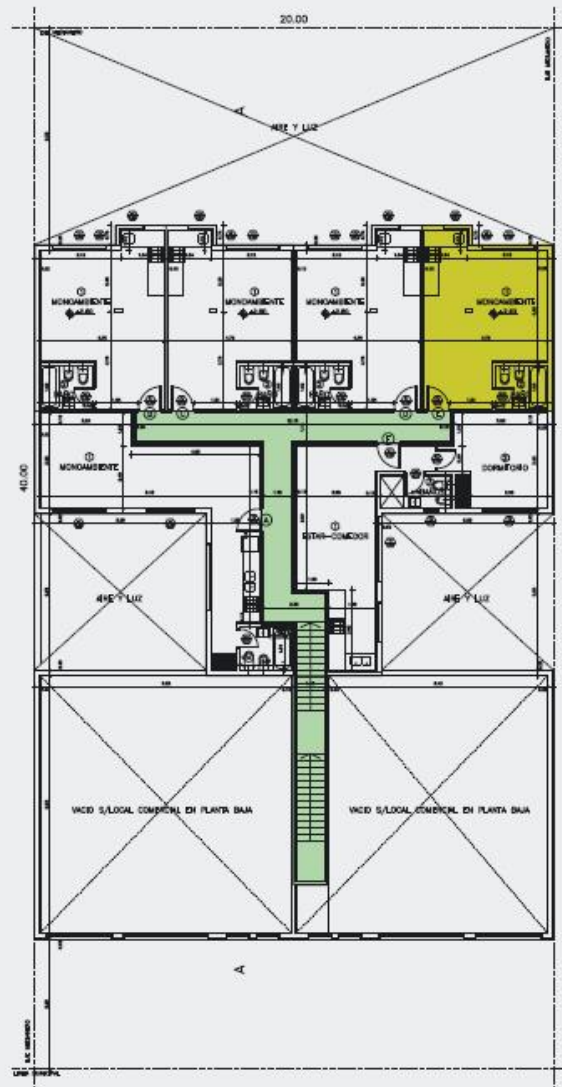

1er Piso

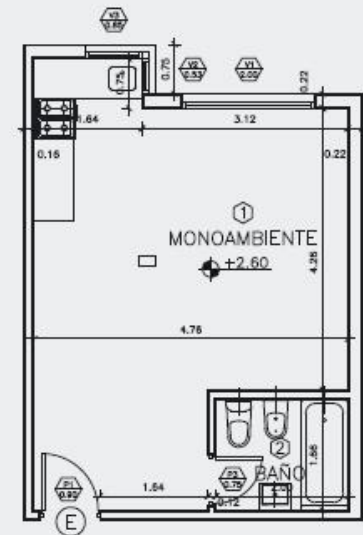

Unidad E
1er Piso

Ambiente único 29,65 m²
Baño 3,35 m²

Sup. Total 33 m²

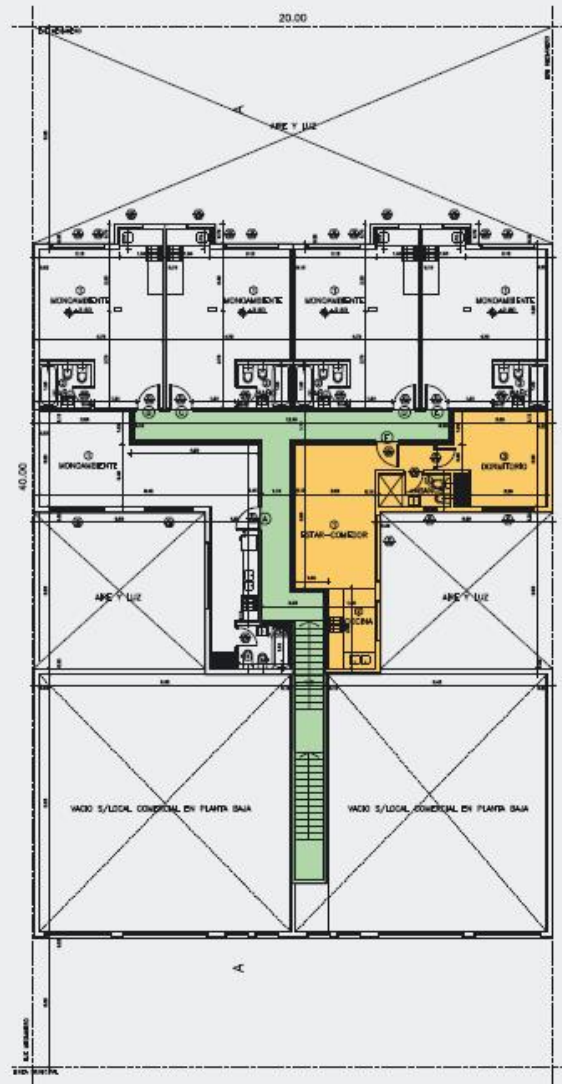

1er Piso

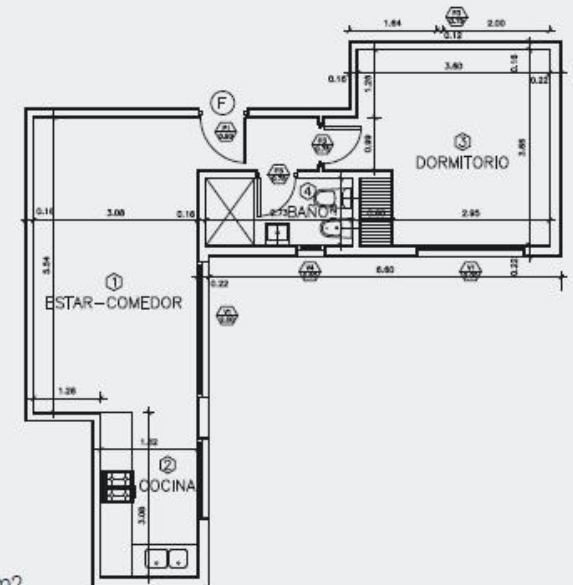

Unidad F
1er Piso

Cocina 5,6 m²
Dormitorio 13,7 m²
Estar / Comedor 25,3 m²
Baño 3,4 m²

Sup. Total 48 m²

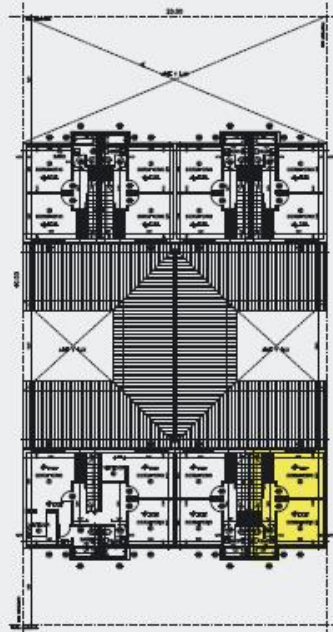

Entre Techo

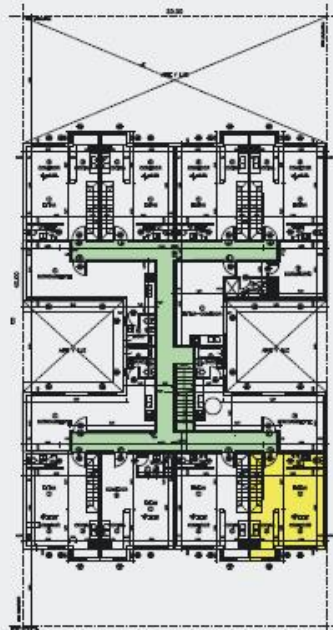

2do Piso

1° Piso



Entre Techo



2do Piso

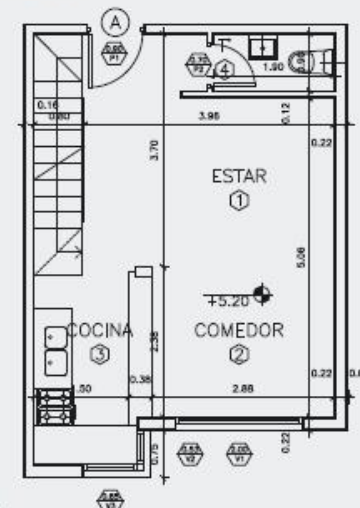

Entre Techo

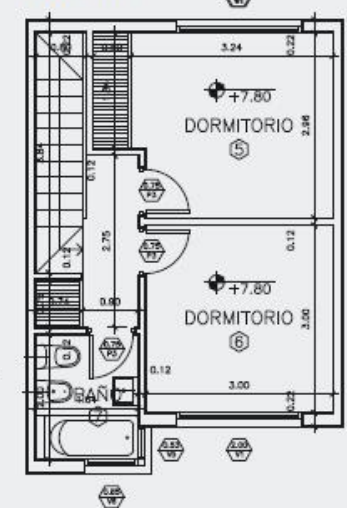

Unidad A
2do Piso

Estar / Comedor 29,65 m²
Cocina 5,7 m²
Toilette 1,7 m²
Dormitorio 1 - 10,4 m²
Dormitorio 2 - 9 m²
Baño 3,25 m²

Sup. Total 62 m²

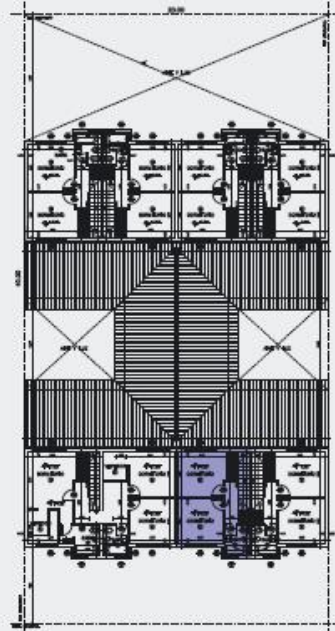

Entre Techo

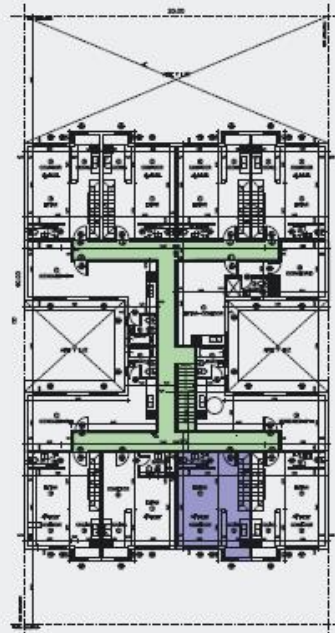

2do Piso

1° Piso



Entre Techo



2do Piso

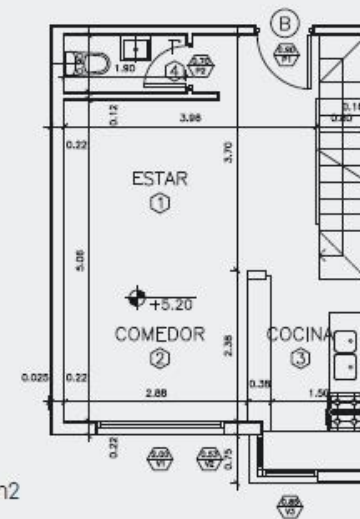

Entre Techo

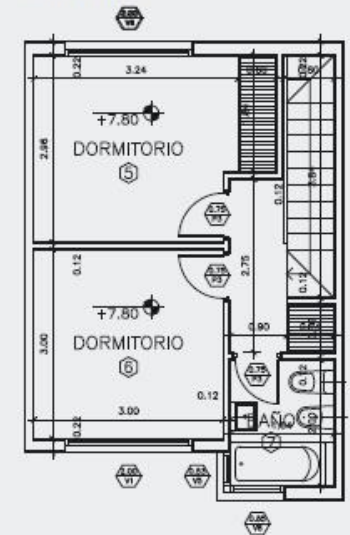

Unidad B

2do Piso

Estar / Comedor 29,65 m²
Cocina 5,7 m²
Toilette 1,7 m²
Dormitorio 1 - 10,4 m²
Dormitorio 2 - 9 m²
Baño 3,25 m²

Sup. Total 62 m²

2do Piso

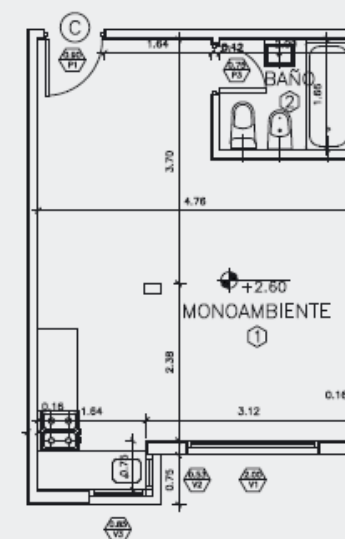
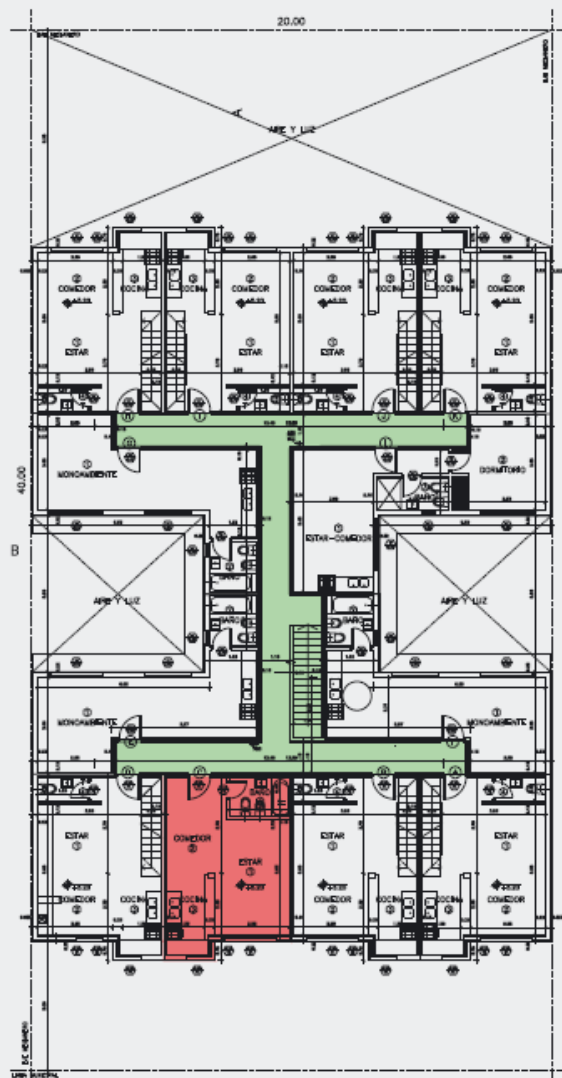

Unidad C 2do Piso

Ambiente Único 24,95 m²
Cocina 5,7 m²
Baño 3,35 m²

Sup. Total 33 m²

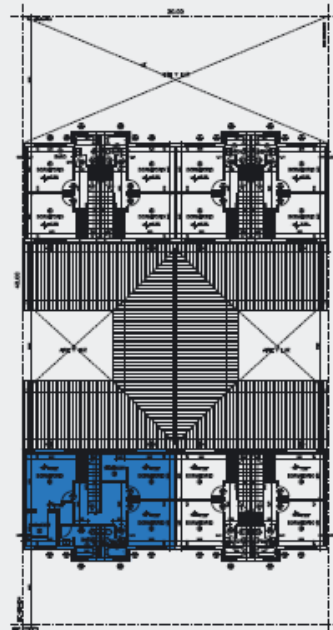

Entre Techo

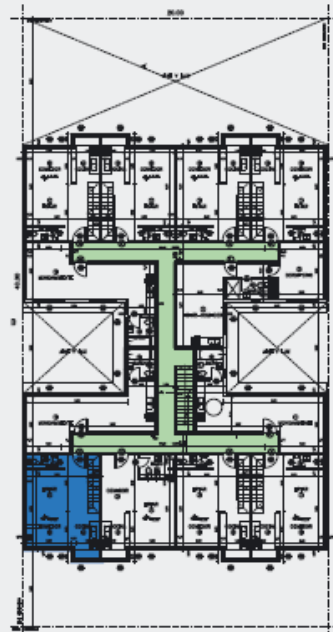

2do Piso

Entre Techo

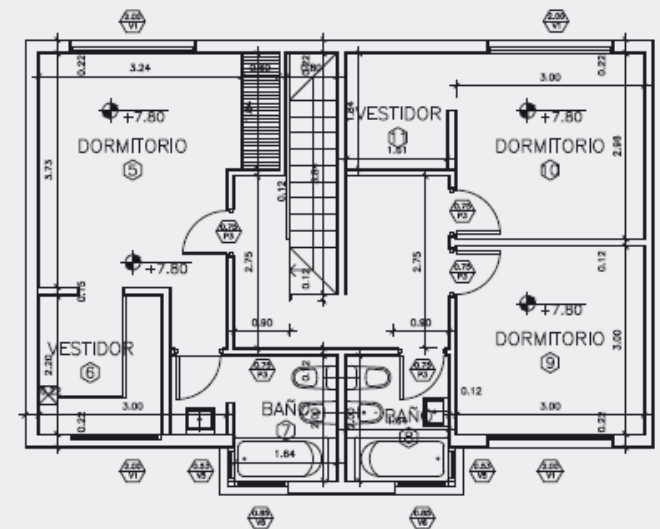

2do Piso

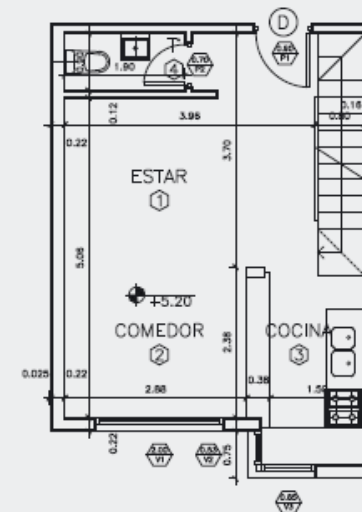

Unidad D
2do Piso

Estar / Comedor 25,6 m²
 Cocina 5,7 m²
 Toilette 1,7 m²
 Dormitorio 1 - 18,9 m²
 Dormitorio 2 - 15,4 m²
 Dormitorio 3 - 9 m²
 Baño 1 - 4,6 m²
 Baño 2 - 3,25 m²

Sup. Total 95 m²

2do Piso

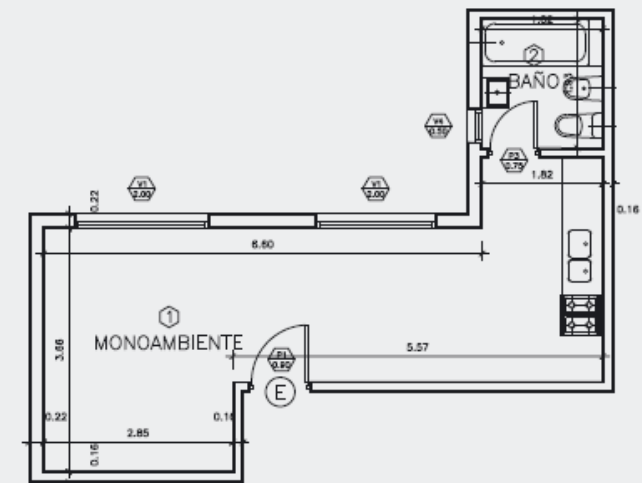
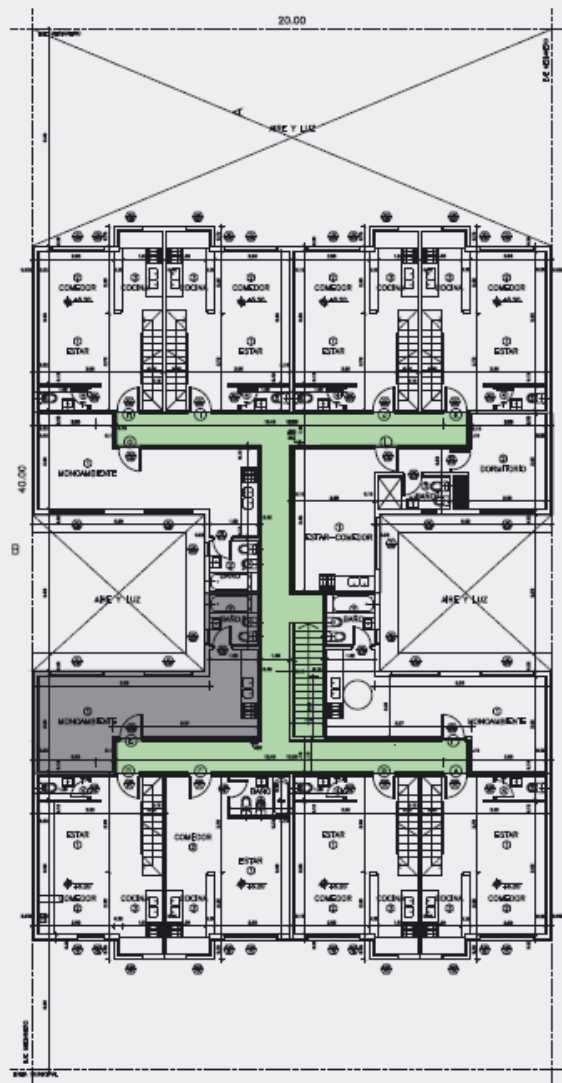

Unidad E 2do Piso

Ambiente único 26,2 m²
Cocina 3,3 m²
Baño 3,5 m²

Sup. Total 33 m²

2do Piso

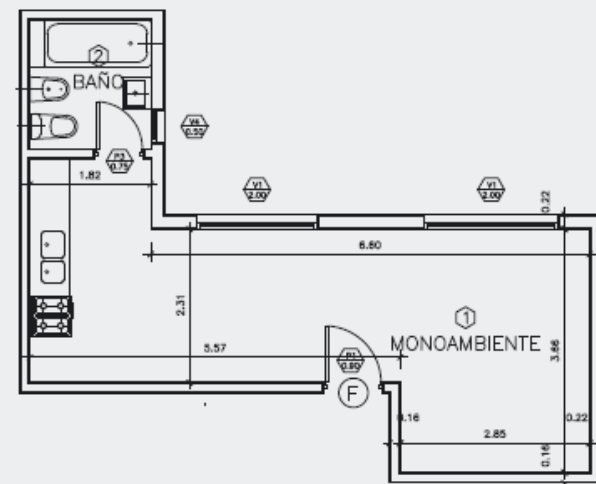
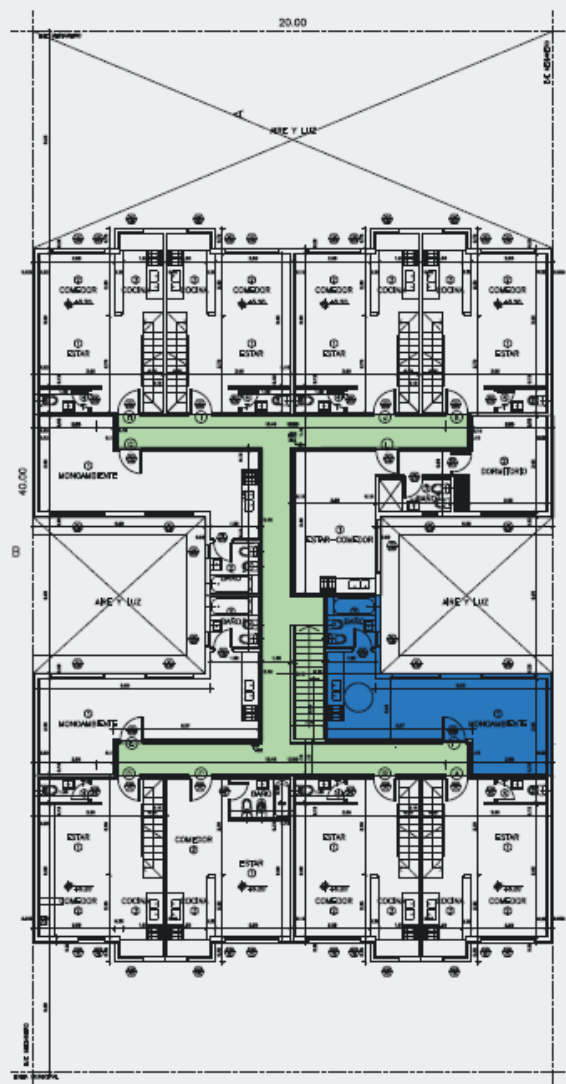

Unidad F 2do Piso

Ambiente único 26,2 m²
Cocina 3,3 m²
Baño 3,5 m²

Sup. Total 33 m²

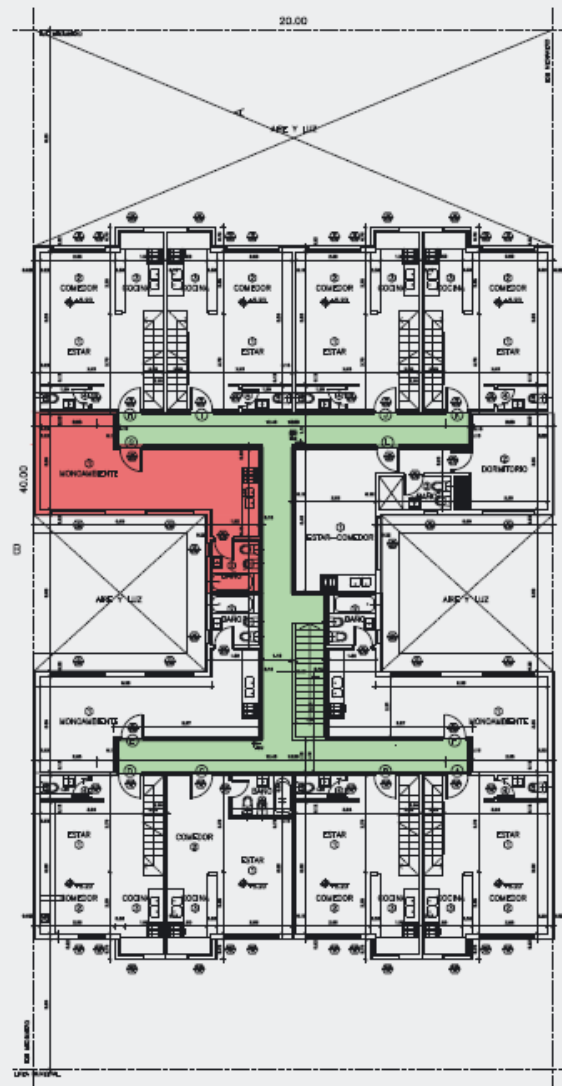

2do Piso

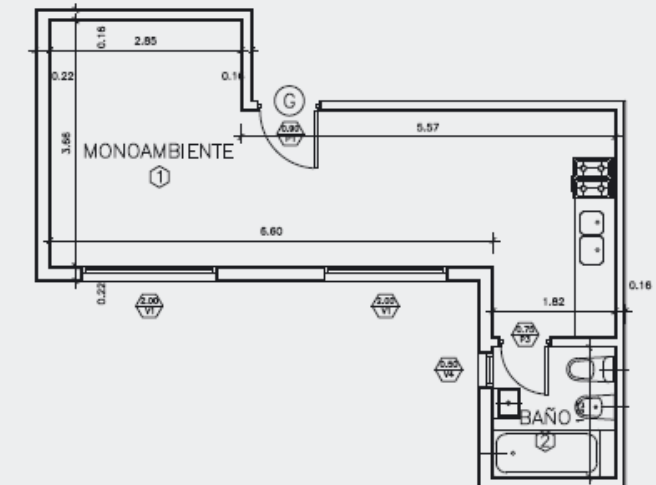

Unidad G
2do Piso

Ambiente único 26,2 m²
Cocina 3,3 m²
Baño 3,5 m²

Sup. Total 33 m²

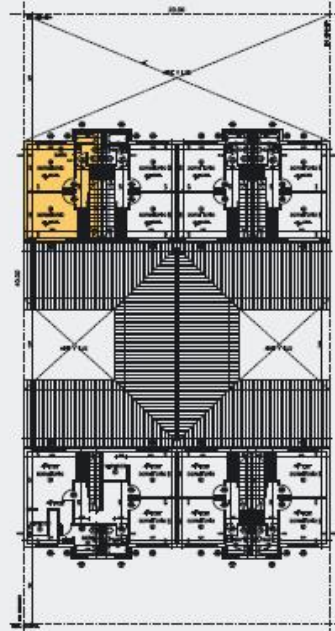

Entre Techo

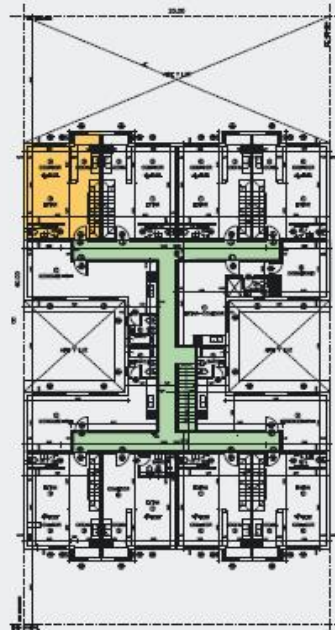

2do Piso

1° Piso



Entre Techo



2do Piso

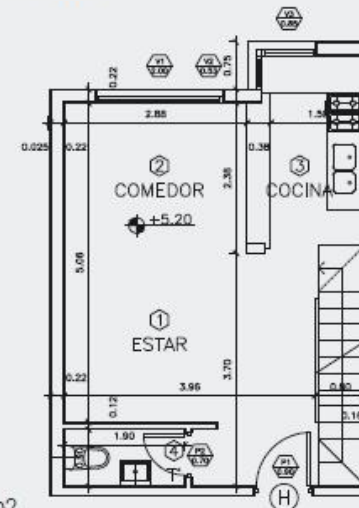

Entre Techo

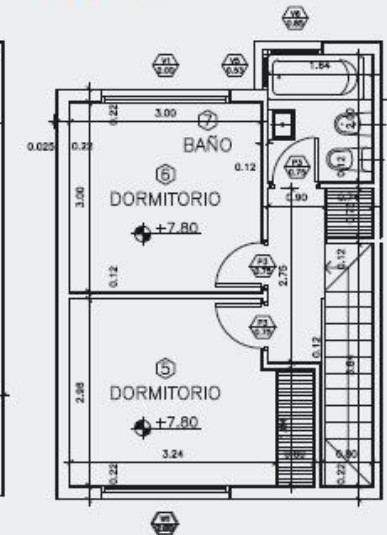

**Unidad H
2do Piso**

- Estar / Comedor 29,65 m²
- Cocina 5,7 m²
- Toilette 1,7 m²
- Dormitorio 1 - 10,4 m²
- Dormitorio 2 - 9 m²
- Baño 3,35 m²

Sup. Total 62 m²

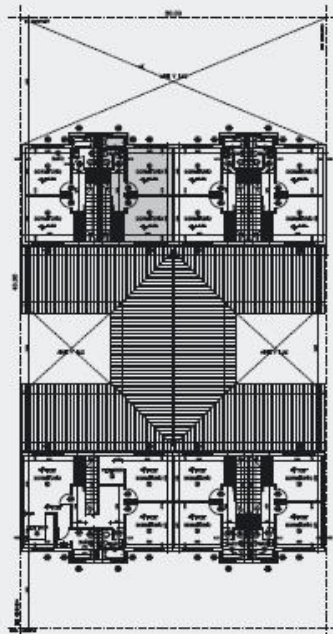

Entre Techo

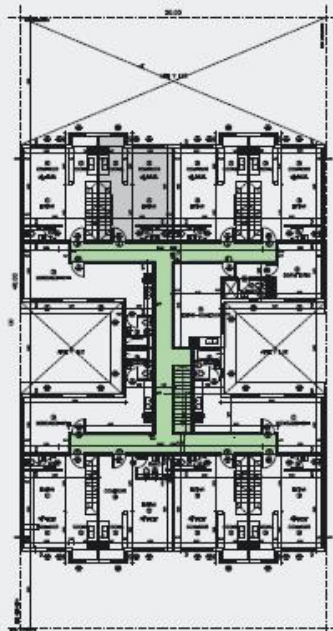

2do Piso

1° Piso



Entre Techo



2do Piso

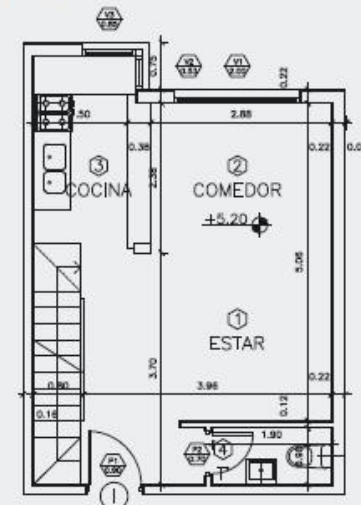

Entre Techo

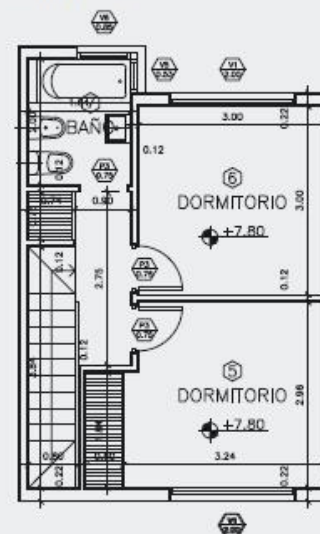

**Unidad I
2do Piso**

- Estar / Comedor 29,65 m²
- Cocina 5,7 m²
- Toilette 1,7 m²
- Dormitorio 1 - 10,4 m²
- Dormitorio 2 - 9 m²
- Baño 3,35 m²

Sup. Total 62 m²

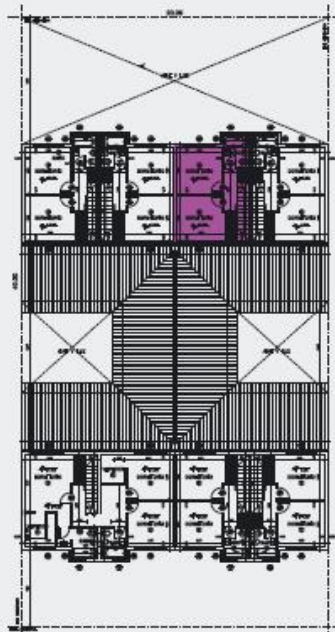

Entre Techo

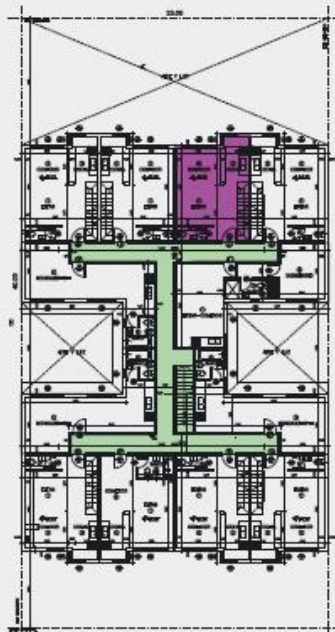

2do Piso

1° Piso



Entre Techo



2do Piso

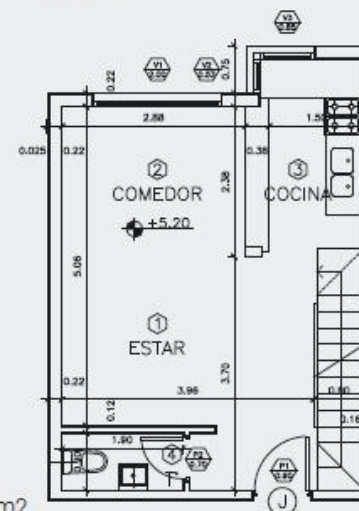

Entre Techo

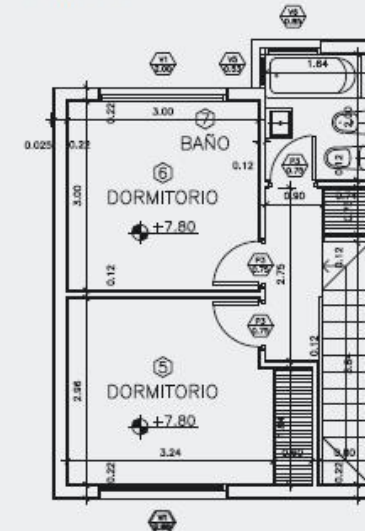

Unidad J
2do Piso

Estar / Comedor 29,65 m²
Cocina 5,7 m²
Toilette 1,7 m²
Dormitorio 1 - 10,4 m²
Dormitorio 2 - 9 m²
Baño 3,35 m²

Sup. Total 62 m²

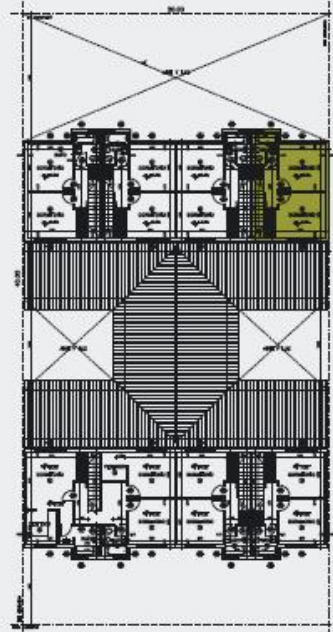

Entre Techo

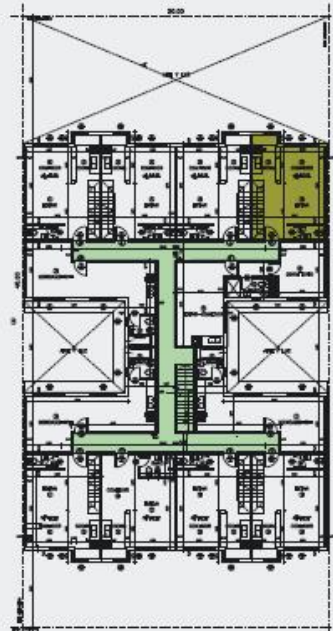

2do Piso

1° Piso



Entre Techo



2do Piso

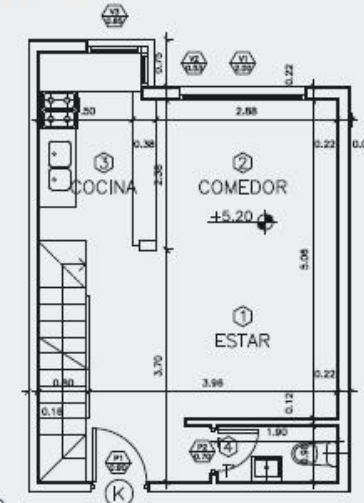

Entre Techo

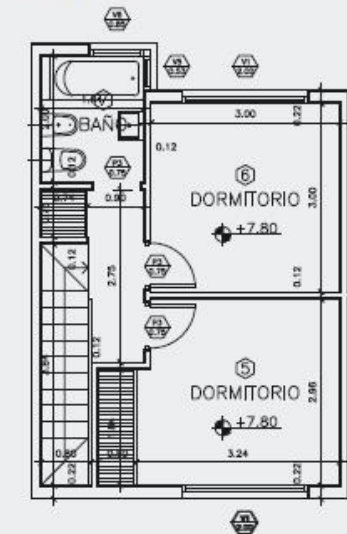

Unidad K
2do Piso

Estar / Comedor 29,65 m²
Cocina 5,7 m²
Toilette 1,7 m²
Dormitorio 1 - 10,4 m²
Dormitorio 2 - 9 m²
Baño 3,35 m²

Sup. Total 62 m²

2do Piso

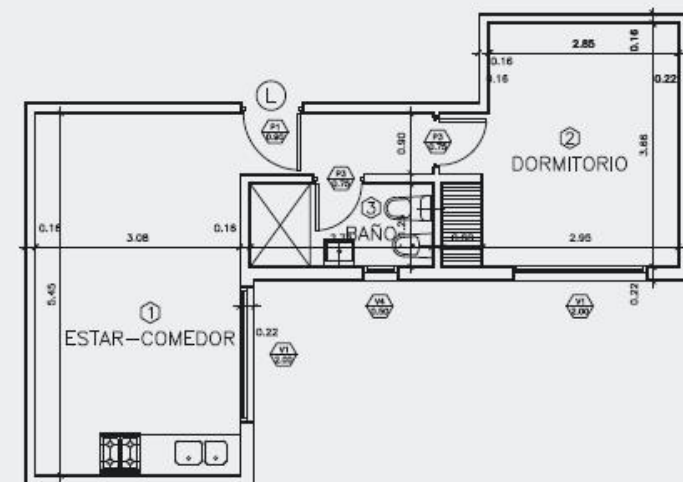
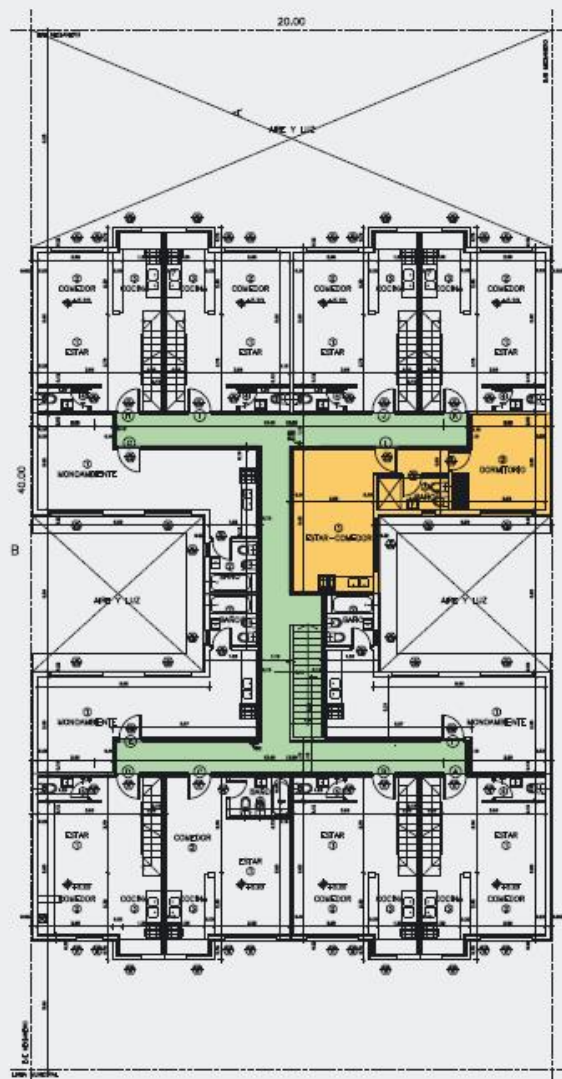

Unidad L 2do Piso

Estar / Comedor 20,8 m²
Dormitorio 12,4 m²
Cocina 3,4 m²
Baño 3,4 m²

Sup. Total 40 m²

